

**JAYO DEVELOPMENT INC.
10564 W. BUSINESS PARK LANE
BOISE, ID 83709
OFFICE: 208-322-3664 FAX: 208-322-3664**

PARAMOUNT PARKS AT THE HIGHLANDS ASSISTED LIVING

THE GENERAL CONTRACTORS SPECIFICATIONS FOR THE SCOPE OF WORK TO BE PERFORMED. NO EXCLUSIONS.

DESCRIPTION: DOORS, HARDWARE, INTERIOR TRIMS AND MOLDINGS

SPECIFICATIONS:

1. INCLUDE SUPPLY AND DELIVERY OF INTERIOR / EXTERIOR DOORS AND TRIM AS SPECED ON PLANS OR AS OUTLINED HERE EXCLUDING HOLLOW METAL DOORS AND JAMBS. INCLUDES SUPPLY AND DELIVERY OF ALL INTERIOR TRIMS, MOLDINGS AND SHELVING AS PER PLANS. HARDWARE FOR DOORS TO INCLUDE HINGES, HANDI-CAP THRESHOLDS, DOOR STOPS AND BIFOLD PULL KNOBS AS PER SPECS.
2. INCLUDES ALL MATERIALS FOR THE INSTALLATION OF HAND RAIL SYSTEM ALONG CORRIDOR WALLS, HANDRAILS ARE NOT SHOWN ON PLANS! INCLUDES A 1X6 BACKER ATTACHED TO THE WALL WITH A 2X4 SPACER ATTACHED TO THE BACKER WITH A 1X6 HAND RAIL. THE HANDRAIL TO INCLUDE AN INSIDE SMOOTH ROUTERED GROOVE FOR GRIP AT THE TOP INSIDE PORTION. HAND RAILS ARE ALL STAIN GRADE AND ARE LOCATED IN THE MEMORY CARE AND ASSISTED LIVING CORRIDOR'S ONLY. NOTE THAT ALL UNIT PRICES AND LINEAR FOOTAGE PRICES ON PROPOSAL NEED TO REMAIN THE SAME THROUGH OUT THE DURATION OF THE PROJECT REGARDLESS OF THE AMOUNT ACTUALLY DELIVERED.
PLEASE QUOTE HAND RAILS SEPARATELY, SEE ATTACHED DETAIL.
3. ALL INTERIOR TRIM WILL BE 1X4 DOOR CASINGS & 1X6 BASE BOARD UNLESS NOTED OTHERWISE. STAINED ALDER TRIM IN COMMON AREAS AND MDF PAINT GRADE IN NON-COMMON AREAS.
4. INCLUDE A TRIM IN COMMON AREAS STAIN GRADE FOR COLUMNS AND CEILING BEAMS.
5. ALL WINDOWS DRYWALL WRAP 3 WAYS WITH EXTENDED SILLS STAINED ALDER IN THE COMMON AREAS AND PAINT GRADE IN THE NON-COMMON AREAS.
6. ALL INTERIOR DOORS OPEN TO COMMON AREAS WILL BE FIR RAISED TWO PANEL INCLUDING RESIDENT UNITS. ALL DOORS NOT OPEN TO COMMON AREAS LIKE INSIDE RESIDENT UNITS OR STAFF WORK STATIONS WILL BE RAISED TWO PANEL PAINT GRADE.

7. THE WINDOWS IN THE FOLLOWING COMMON AREAS WILL RECEIVE FULL WOOD WRAP STAINED ALDER:

- DINING ROOMS
- LIVING ROOMS
- VESTIBULES
- BISTRO
- BILLIARD
- PARAMOUNT ROOM
- PRIVATE DINING A102
- GRAND FOYER
- FAMILY A108
- DINING A106
- LIVING A113

8. THE FOLLOWING AREAS WILL BE FINISHED OUT WITH STAINED ALDER, COLUMN'S / ARCHES IN THESE AREAS WILL WRAP WITH ALDER. WALL CAPS WILL BE ALDER & THE FIREPLACE DETAILS, THE COMMON AREAS INCLUDE:

- ALL CORRIDOR'S
- LOBBIES
- PARAMOUNT ROOM
- DINING ROOMS
- VESTIBULES
- BISTRO
- ELEVATOR LOBBY
- DINING ROOMS
- PRIVATE DINING ROOMS
- PUBLIC RESTROOMS
- THEATER
- STAIRS
- RECEPTION
- GRAND FOYER
- FAMILY ROOM
- CHAPEL
- LIBRARY
- LIVING ROOM
- CONFERENCE ROOM
- LOUNGE
- BILLIARD

PLEASE REVIEW ALL A DRAWINGS FOR DETAILS AND INFORMATION

Please contact Cameron Jayo for bid Dates, to submit bids and for any additional bid information at:
cameron.paramountparks@gmail.com

THE SUB CONTRACTOR PROPOSAL INCLUDES BUT IS NOT LIMITED TO THE ITEMS ABOVE, THE SUB CONTRACTOR UNDERSTANDS THE ALL ITEMS MUST BE AS PER PLAN AND MEET LOCAL BUILDING CODE REQUIREMENTS UNLESS NOTED OTHERWISE.

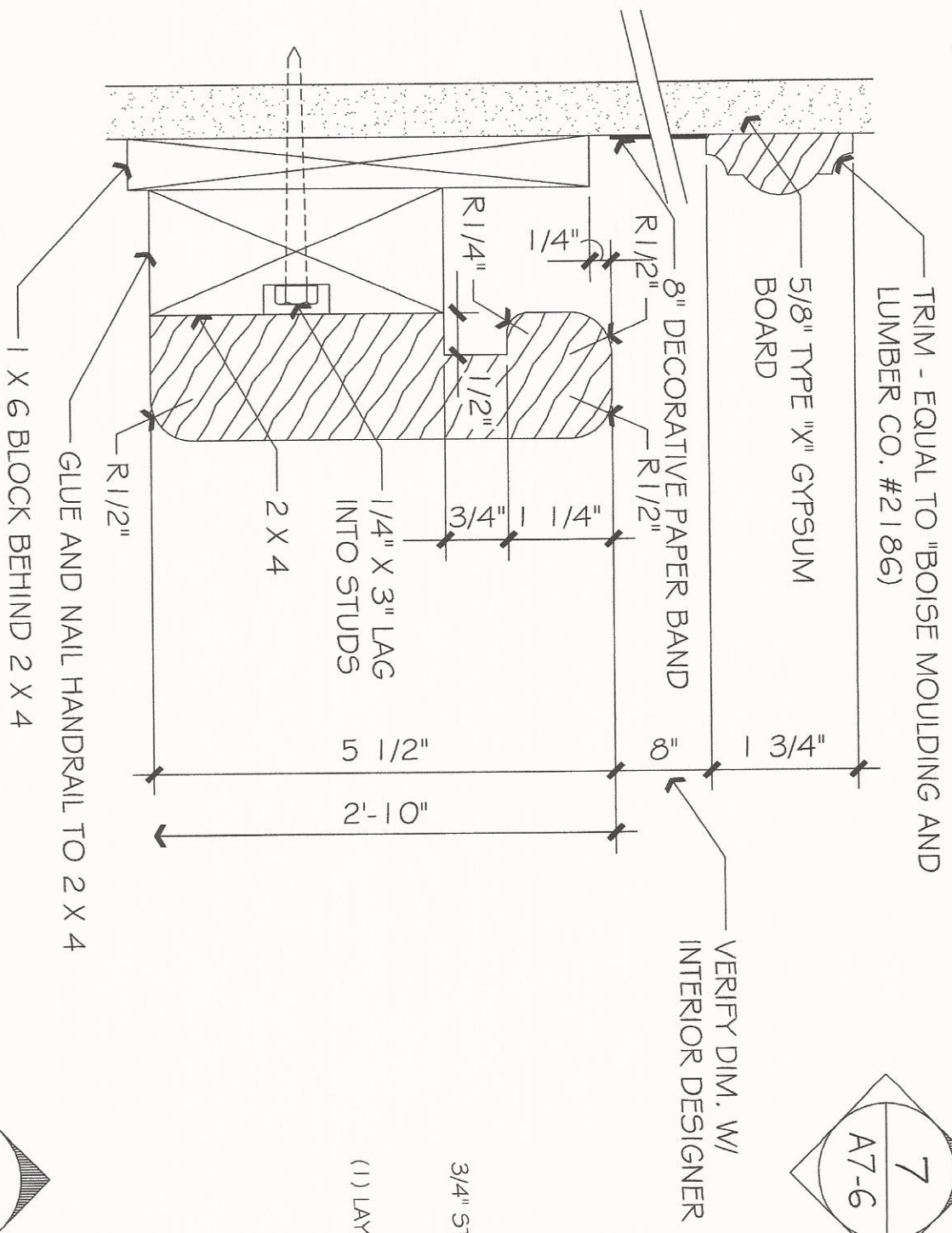

DETAIL

SCALE : 6" = 1'-0"

HANDRAIL

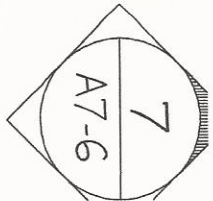

VERIFY DIM. W/
INTERIOR DESIGNER

3/4" ST/

(1) LAYE

